



CURTAIN SYSTEM

INSTALLATION MANUAL

CONTENTS

- SECTION A: | ITEMS REQUIRED** 01
- AVAILABLE IN US, AU, EU01
- SECTION B: | INSTALLATION** 02
- CEILING/ TOP FIX BRACKETS02
- SINGLE FACE FIX BRACKET03
- SECTION C: | MOTOR INSTALLATION** 05
- CONVENTIONAL ROUTING05
- ALTERNATIVE ROUTING05
- SECTION D: | DRAPE INSTALLATION** 06
- INSTALLATION - SINGLE FACE FIX BRACKET06

DISCLAIMER

INTRODUCTION

This Product Specifications manual for CURTAIN SYSTEM has been produced by Rollease Acmeda to supply the necessary information for the safe and correct installation of CURTAIN SYSTEM.

DISCLAIMER

Rollease Acmeda has used reasonable care in preparing the information included in this document, but makes no representations or warranties as to the completeness or accuracy of the information. Information is supplied upon the condition that the persons receiving the information will make their own determination as to its suitability for their purposes prior to use. Rollease Acmeda assumes no liability whatsoever for any damages incurred by you resulting from errors in or omissions from the information included herein. Rollease Acmeda reserves the right to make changes without further notice to any products to improve reliability, function or design.

COPYRIGHT

COPYRIGHT © ROLLEASE ACMEDA

All rights are reserved. No part of this document may be reproduced or utilised in any means, by any means, electronic or mechanical including photocopying, recordings, or by any information storage or retrieval system, without the express permission from Rollease Acmeda.



SECTION A: | ITEMS REQUIRED

AVAILABLE IN US, AU, EU

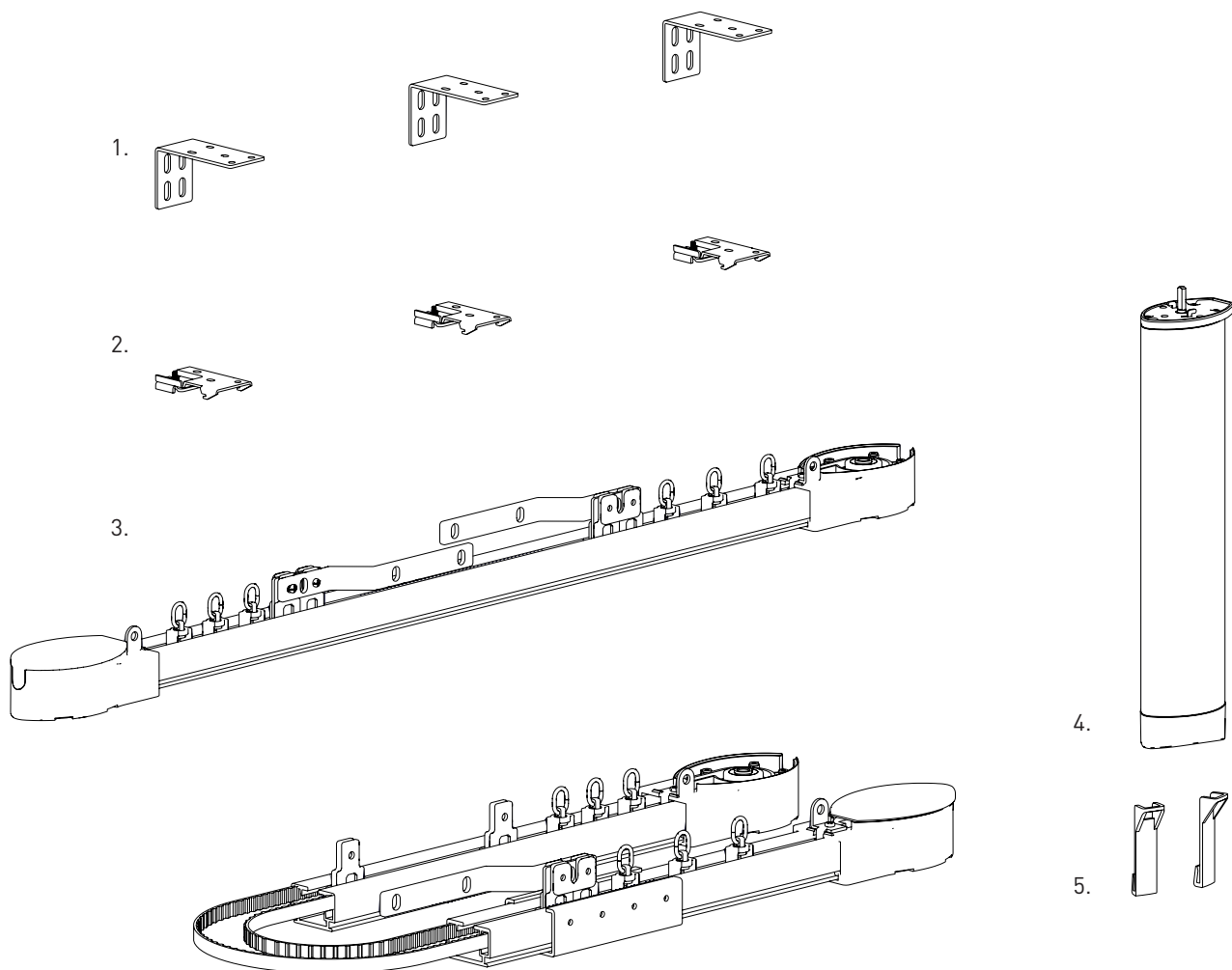

SYSTEM INDEX:

1. Single Face Fix Bracket
2. Ceiling Bracket
3. Drape Track (Pre-Assembled)
4. Automate C - ARC Drape Motor
5. End Hooks

CEILING/ TOP FIX BRACKETS

STEP 1 - ATTACH CEILING BRACKETS TO CEILING

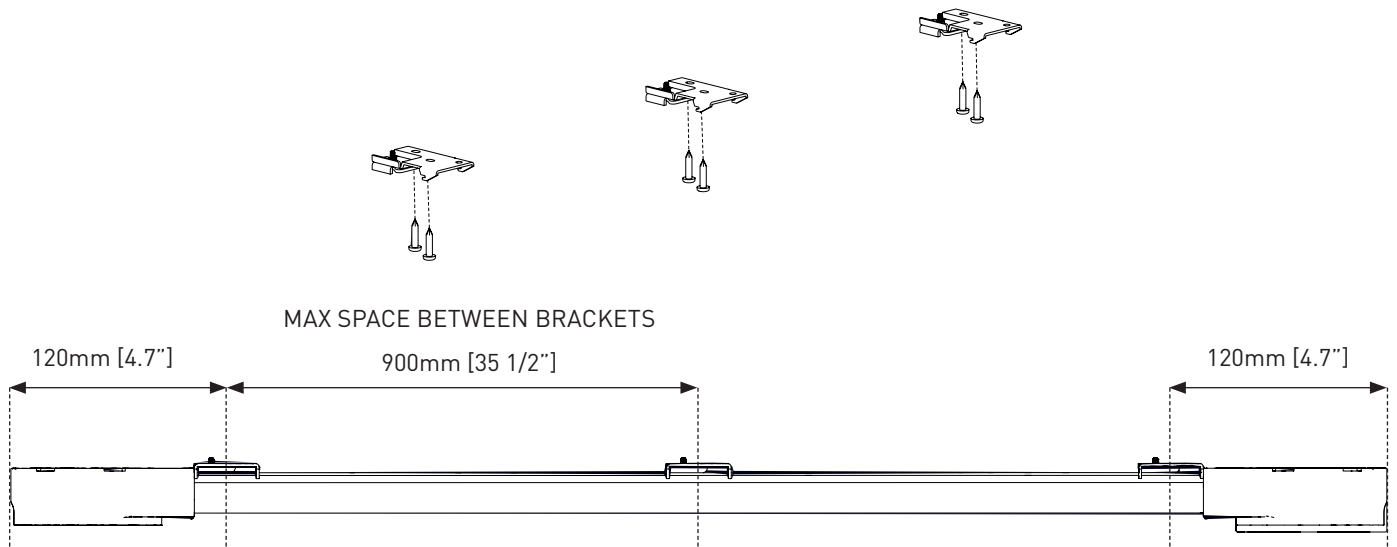

STEP 2 - ENSURE ALIGNMENT IS STRAIGHT

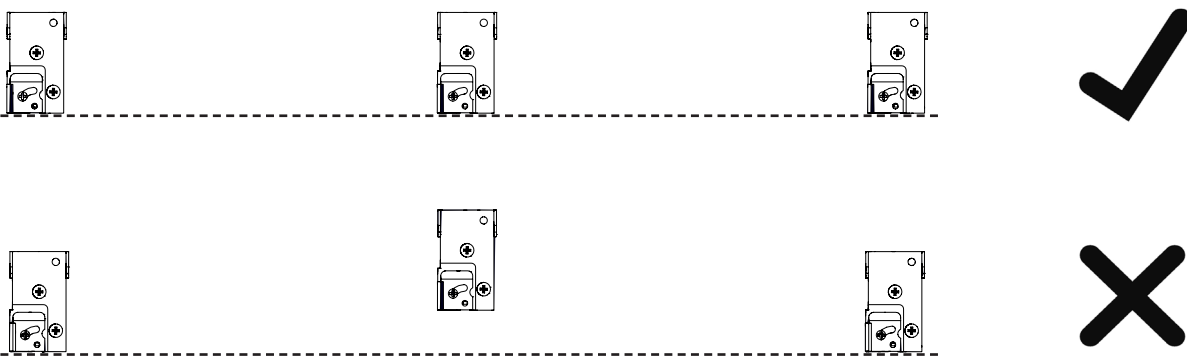

STEP 3 - ATTACH DRAPE TRACK (ASSEMBLED) TO CEILING BRACKETS

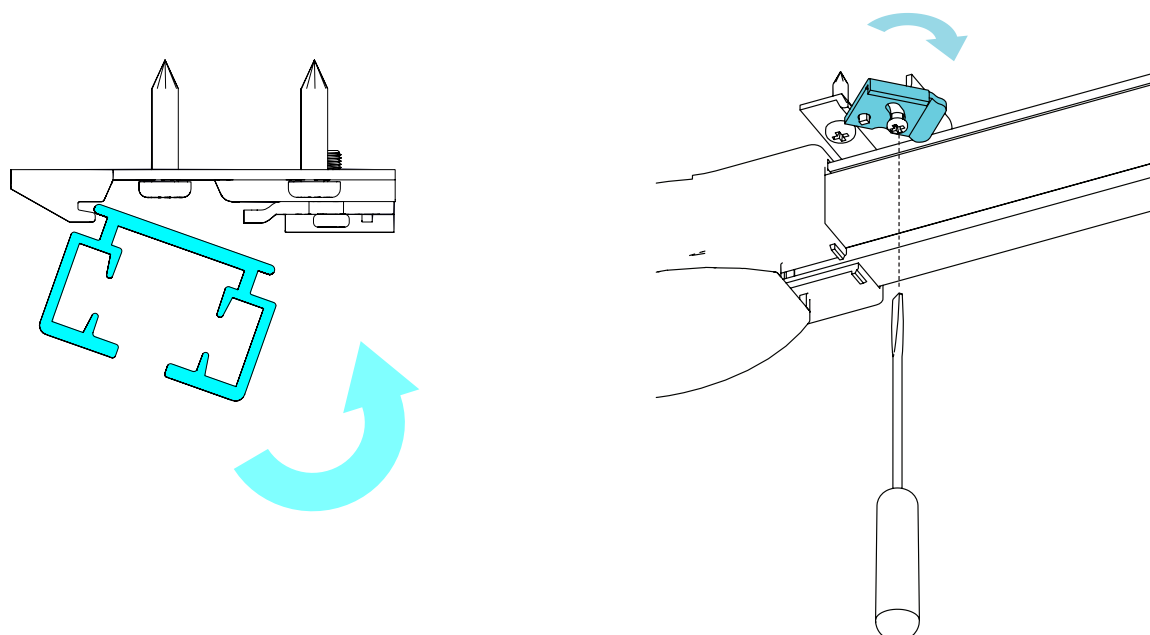

SINGLE FACE FIX BRACKET

STEP 1 - ATTACH CEILING BRACKET TO SINGLE FACE FIX BRACKET

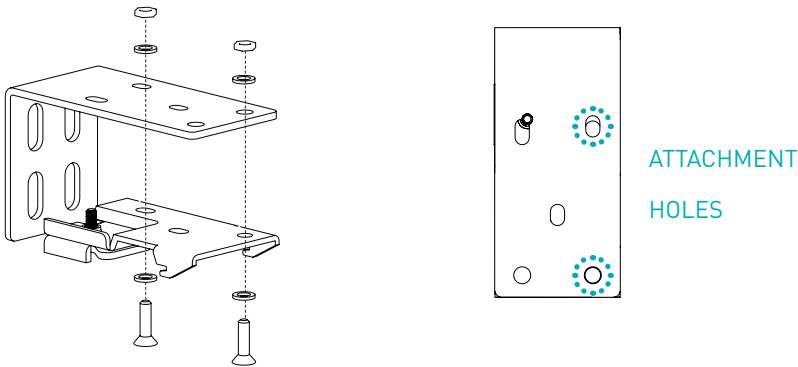

STEP 2 - ATTACH ASSEMBLED BRACKET TO WALL

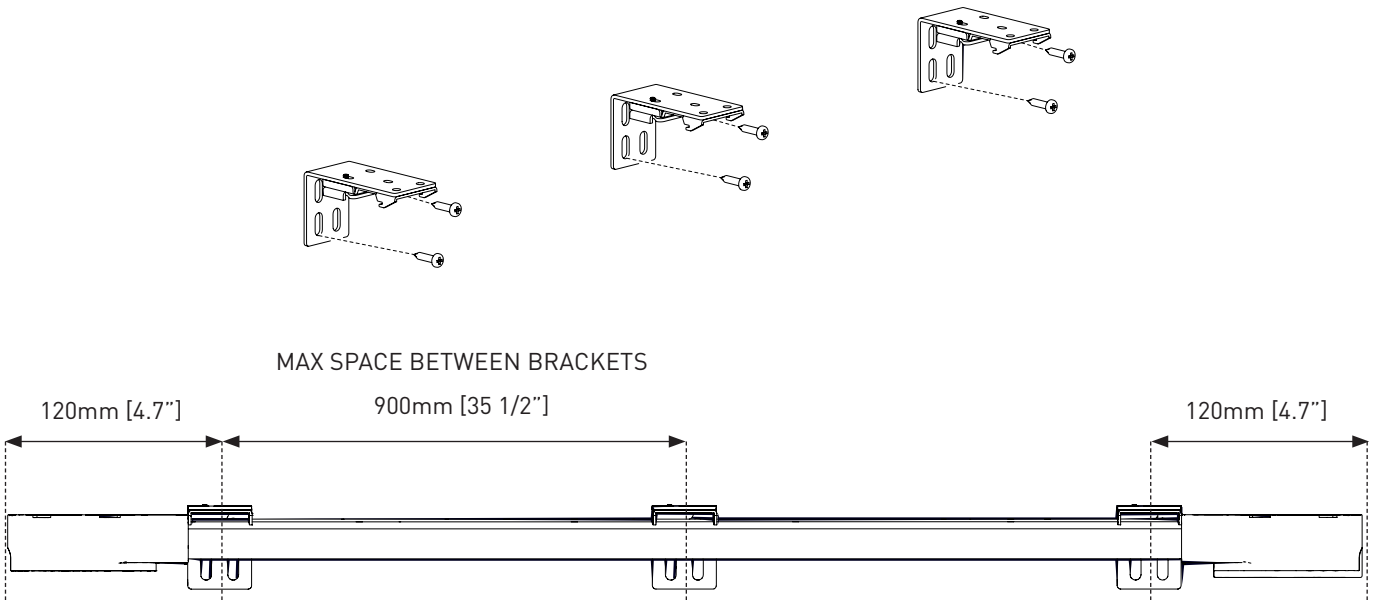

STEP 3 - ADJUSTMENT AS REQUIRED

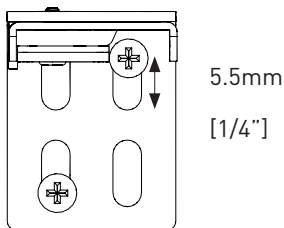

STEP 4 - ENSURE STRAIGHT ALIGNMENT

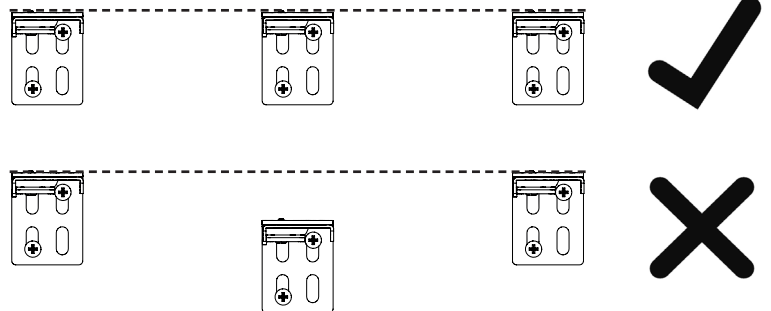

SINGLE FACE FIX BRACKET

STEP 5 - ATTACH DRAPE TRACK (ASSEMBLED) TO SINGLE FACE FIX BRACKET

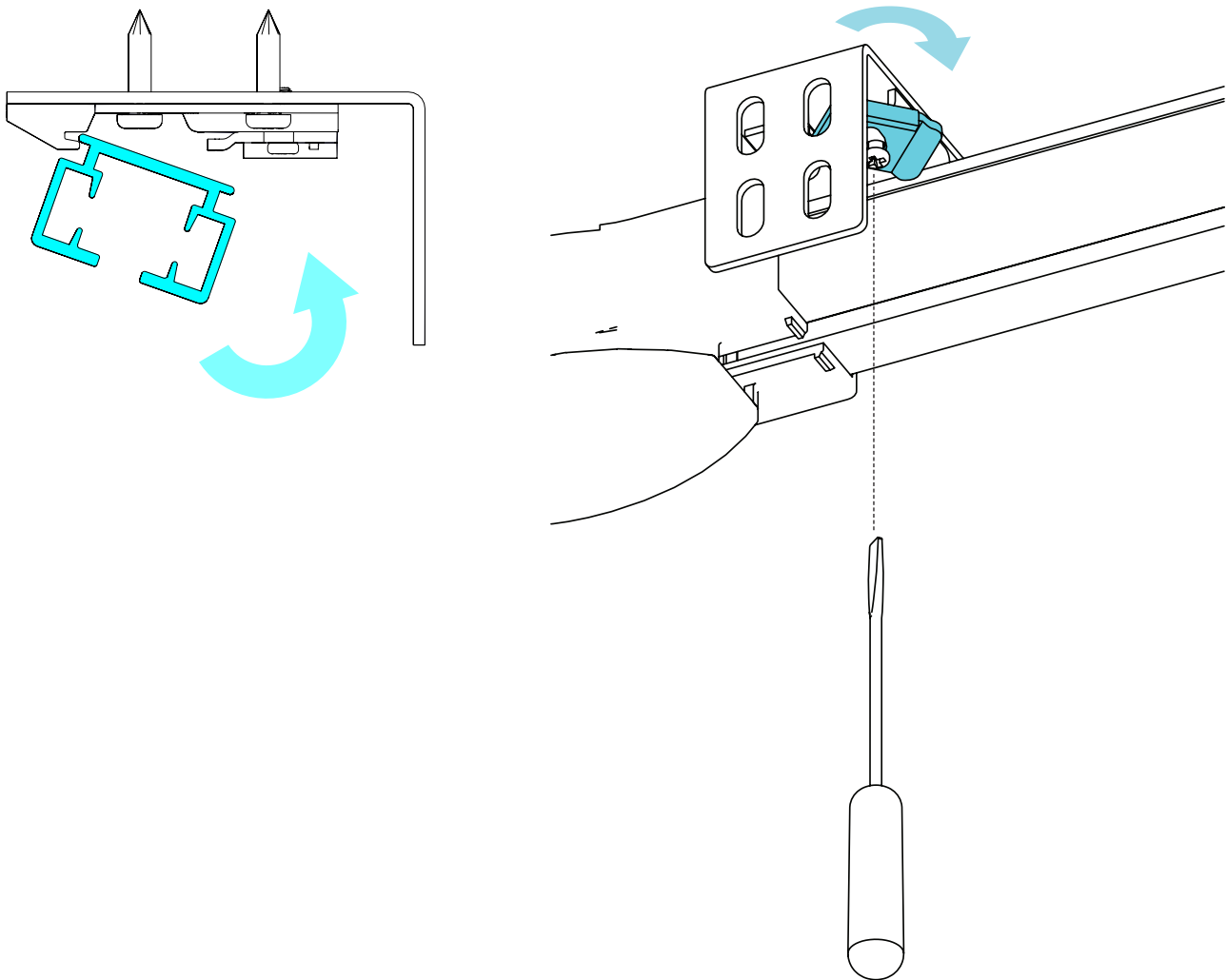

CONVENTIONAL ROUTING

ATTACH MOTOR INTO DRIVE UNIT. LOCK THE MOTOR BY RETRACTING AND SLIDING THE PIN INTO THE LOCK POSITION.

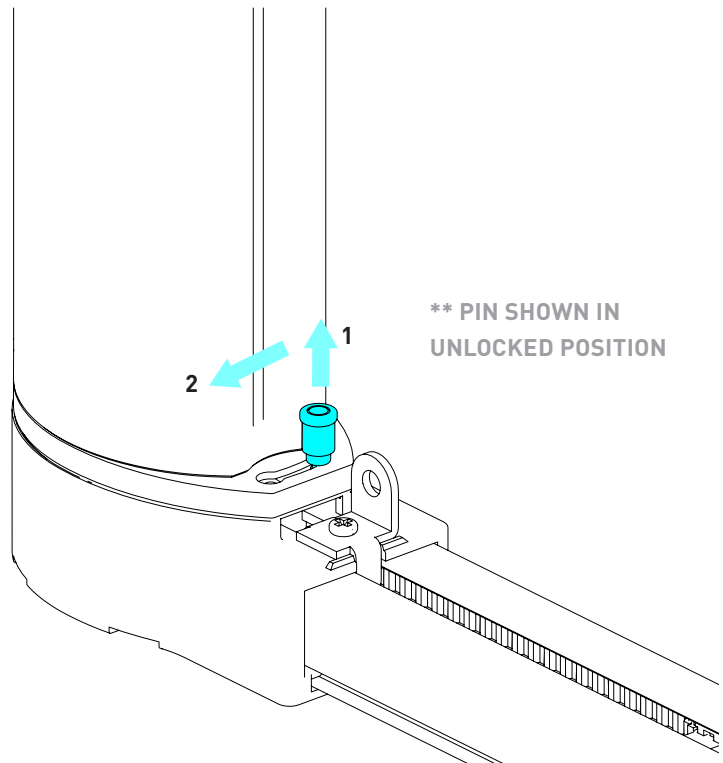
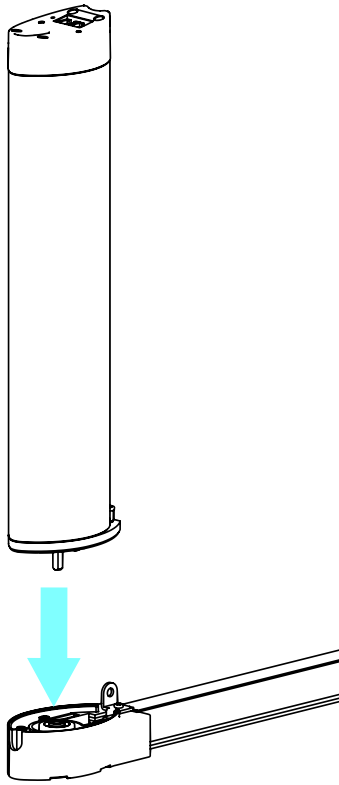

ALTERNATIVE ROUTING

THE MOTOR POWER CABLE CAN BE ROUTED THROUGH THE DRAPE MOTOR FOR NEATER INSTALLATIONS.

